

SRAM® S7 TECHNICAL DATA / ASSEMBLY REQUIREMENTS

S7

Caution:
Not suitable for tandems, transport bicycles and similar.

Cycle frame:

- Dropouts must be parallel.
- Slot width at rear dropout 10^{-0.5} mm.
- The strength must be such that with a maximum braking torque of 250 Nm (2200 in.lbs.) on the rear wheel no residual deformation can occur on the rear structure.

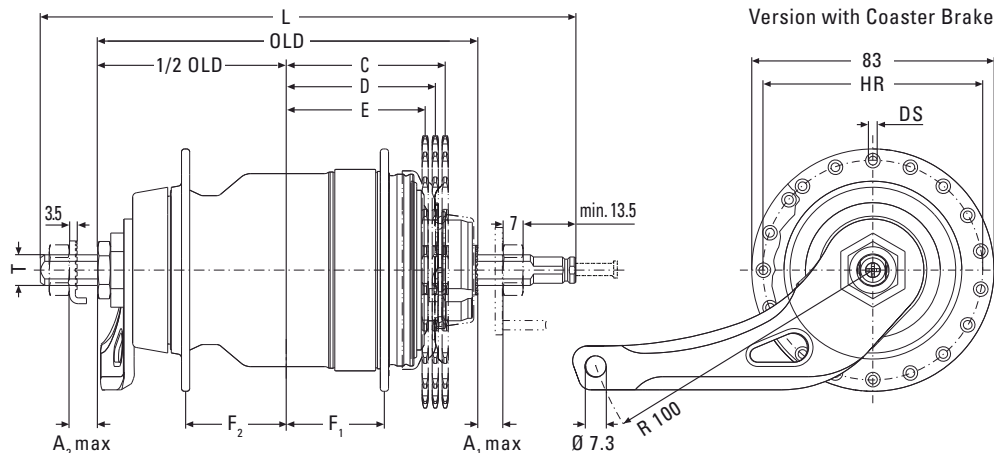

GEAR HUBS

		SRAM S7 with coaster brake	SRAM S7 without brake
	Type	MH 7215	MH 7205
	Brake	With coaster brake	Without brake
	Over Locknut Dim., OLD	130 mm	130 mm
Axle	Length, L	183.4 mm	183.4 mm
	Ends Diameter, T	FG 10.5	FG 10.5
	Dropout Width Dim.	A ₁ max. = 12.5 mm / A ₂ max. = 12 mm	A ₁ max. = 12.5 mm / A ₂ max. = 10 mm
Spoke	Holes	36	36
	Hole Diameter, DS	3.0 mm	3.0 mm
	Hole Ref. ø, HR	75 mm	75 mm
	Flange Dist. to 1/2 OLD	F ₁ = 33 mm / F ₂ = 34 mm	F ₁ = 33 mm / F ₂ = 34 mm
Gear Hub Ratio	Totally	303 %	←
	Speed 1	0,574	←
	Speed 2	0,677	←
	Speed 3	0,809	←
	Speed 4	1,000	←
	Speed 5	1,236	←
	Speed 6	1,476	←
	Speed 7	1,742	←
Chain	Usable Dimensions	1/2" x 1/8" or 1/2" x 3/32"	1/2" x 1/8" or 1/2" x 3/32"
	Line, C/D/E	C = 54 mm / D = 51 mm / E = 48 mm	C = 54 mm / D = 51 mm / E = 48 mm
	Ratio	24", 26", 28" = 1.83 - 1.90 / 20" = 1.83 - 2.00	min. 1.83
Compatibility	Sprocket	16 - 24 Teeth (outward offset - Chain Line C) / 18 Teeth (straight - CL D) / 19 - 24 Teeth (inward offset - CL E)	
	Shifter	SRAM Grip 7	←
	Clickbox	Clickbox S7	←
	Tandem	Not suitable for tandems, transport bicycles or similar	
Finish	Weight	1714 g	1556 g
	Hub Shell Material	Steel	Steel
	Finish	Matt Chrome Plated or Black	Matt Chrome Plated or Black

SRAM® S7

TECHNICAL DATA / ASSEMBLY REQUIREMENTS

SHIFTER

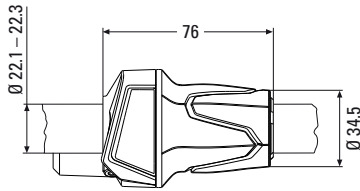

SHIFTER

SRAM Grip 7

Design	Shifter Type	Twist Shifter mit Clickbox							
	Cable Length	Black housing: 1400 mm	1500 mm	1600 mm	1700 mm	1800 mm	1900 mm	Grey housing: 1650 mm	1750 mm
	Gear Indication	Window							
	Clamping Diameter	22.1 – 22.3 mm							
	Straight handlebar ends	Minimum necessary length for shifter and handlebar grip = 150 mm							
	Length of shifter	76 mm							
	Weight	N/A							
	Housing	Glass filled PA, black or grey							
	Grip	PP							
	Grip Cover	Thermoplastic elastomer, Overmolded							
Clamping Collar	Aluminum								

SRAM S7 ASSEMBLY

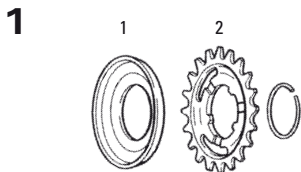

ASSEMBLY HUB

- Lace the wheel as normal. See spoke length table.
 - Place the dust cap (1, Fig. 1) and sprocket (2) on the driver.
- Advice:**
When fitting a straight sprocket (not an offset version), the beadings of the sprocket must lie against the dust cap.

- Push sprocket circlip (3, Fig. 2) onto the cone of tool sleeve (4). Place tool sleeve with large diameter on the driver.
- Push the spring end of sliding sleeve (5) of the tool over the tool sleeve. Thrust sliding sleeve in direction (6), this forces circlip into the recess of the driver.
- Remove tool and check that the circlip is seated correctly.

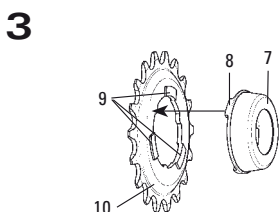
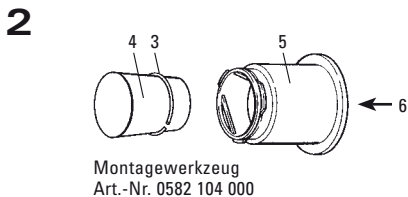

Spoke length table

Tire Size		Cross	Length
47-406	20" x 1.75 x 2	3 x	181 mm
37-490	22" x 1 3/8	3 x	225 mm
47-507	24" x 1.75 x 2	3 x	232 mm
37-540	24" x 1 3/8	3 x	251 mm
47-559	26" x 1.75 x 2	3 x	259 mm
37-590	26" x 1 3/8	3 x	275 mm
47-622	28" x 1.75	3 x	289 mm
37-622	28" x 1 3/8 x 1 5/8	3 x	289 mm
28-622	28" x 1 1/8	3 x	289 mm
32-622	28" x 1 5/8 x 1 1/4	3 x	289 mm
28-630	27" x 1 1/4 fifty	3 x	294 mm
32-630	27" x 1 1/4	3 x	294 mm

Spoke lengths are approximate values. They must be checked through lacing attempts and adjusted accordingly.

4

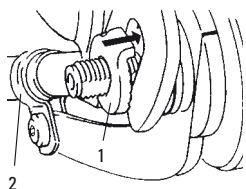

5

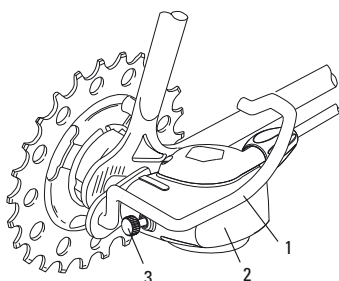

6

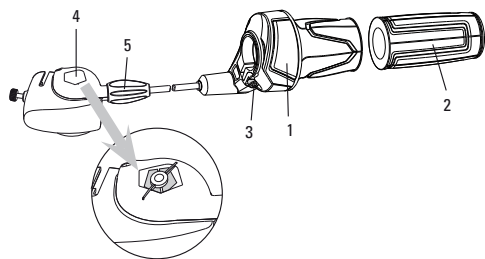

7

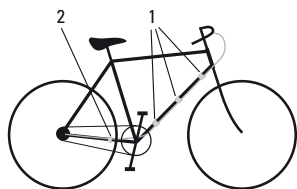

8

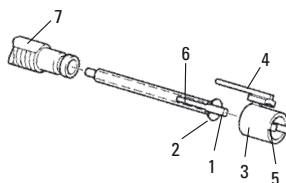

- Turn dust cap (7, Fig. 3) until the three lugs (8) are between the three beads (9) on the sprocket (10).
- Position dust cap and push towards sprocket until it is felt to lock into place.
- Placing the wheel in the rear frame.
- Fit new retaining washer (3,5 mm thick) on left axle end (1, Fig. 4).

The serrations must bear against the dropout and the lug must engage in the dropout slot.

- Fit the hoop guard (1, Fig. 5) on the right axle side (drive side). No additional washers or any accessories are permitted.

Advice:
If a different protective bracket is used the thickness of the attachment plate must be max. 3 mm.

At least the beginning of the axle thread must be visible in front of the axle nut.

- Mount the axle nuts. Tightening torque on axle nuts 30 – 40 Nm (266 – 350 in.lbs.)
- Version with coaster brake: Mount the brake lever using a suitable frame clamp (2, Fig. 4).

Caution:
Mount the brake lever between the two straps of the frame clamp.

The clamp must be seated on the frame without play.

Use a self-locking nut! Tightening torque: 2 – 3 Nm (18 – 27 in.lbs.).

Caution:
Check that all the brake system components are functioning properly!

ASSEMBLY SHIFTER

Advice:

- When choosing cable housing lengths, be sure to allow enough housing for an extreme turn of the handlebars in both directions.
- Note also, that different stem lengths and handlebar positions effects cable housing length.

- Slide the shifter (1, Fig. 6) onto the handlebar.
- Slide the handlebar grip (2) onto the handlebar.

Caution:
Never use lubricants or solvents when fitting handlebar grips. They have a safety function and must not come free from the handlebar.

- Place the shifter on the handlebar grip and position so that you can use it comfortably. Tighten the clamping bolt (3). 3 mm Allen key, torque 3.5 – 4 Nm (31 – 35 in.lbs.).

Caution:

- Check that shifter and brake lever can be easily operated (if necessary, realign).
- Never ride without handlebar grips. The turning grip of the twist shifter could become loose. This can result in severe injuries.

- When fitting the cable avoid small radius. Attach the cable 3 times to the down tube (1, Fig. 7).

- Last attachment point is on the lower rear wheel fork (2, Fig. 7) immediately behind the chain wheel.

Cable housing must be movable inside attachment.

INSTALLING CLICKBOX

- Insert shift rod (1, Fig. 8) in shift tube (2) (oil parts lightly) and then push into axle bore as far as the stop. Turn slot (6) in shift tube to a position where it is easily visible.

- Push locating sleeve (3) with guiding rib (4) to the front onto the hub axle – making sure that the internal lug (5) is guided in the slot (6) of the shift tube until it can be felt – and heard – to engage.

- Turn locating sleeve on the axle until the guiding rib (4) is facing roughly upwards.

- Place shifter in gear position “1”.
- Push on Clickbox (2, Fig. 5) to the stop on the hub axle. The guiding rib (4, Fig. 8) of the locating sleeve thereby engages in the slot on the housing. In the end position tighten up the knurled bolt (3, Fig. 5) by hand (0.3 Nm / 2.7 in.lbs.).

ADJUSTMENT

- Be sure to reset rotational shifter from 5th to 4th gear.
- Match up the marks in the Clickbox viewing window (4, Fig. 6) by turning the barrel adjuster (5).

Caution:
Check that all the brake system components are functioning properly!

SRAM® S7 MAINTENANCE

1

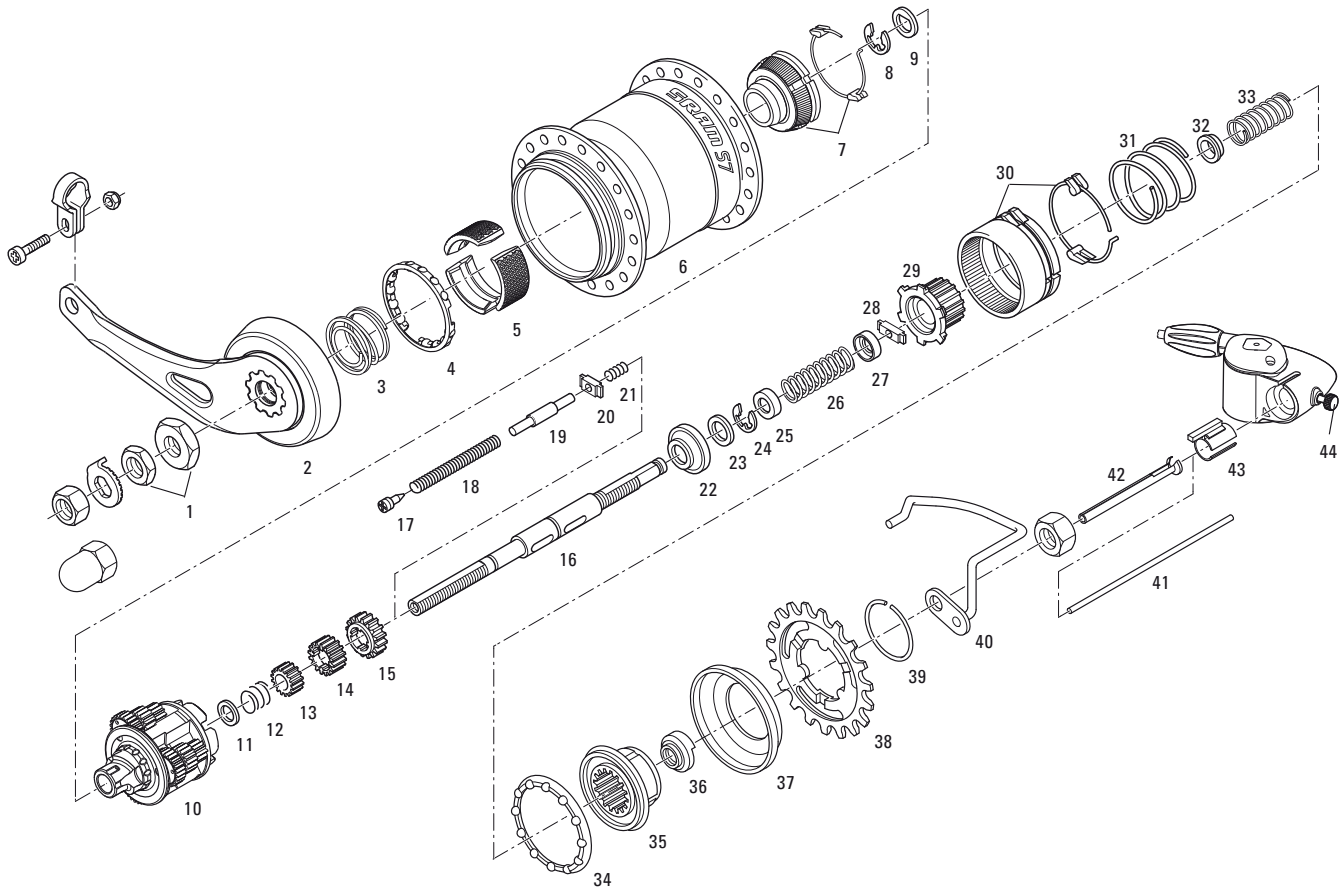

2

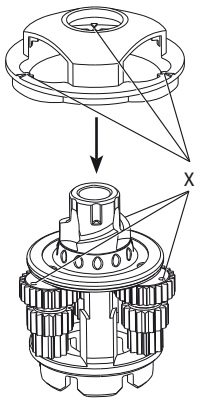

SRAM S7 mounting aid
Part No. 65 0324 103 000

3

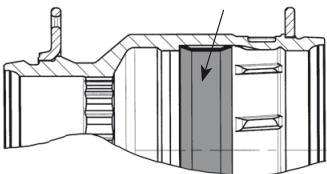

SERVICE

To maintain optimal performance and durability of your components, periodic maintenance is required. We recommend that you have your components serviced every 2 year or 5000 km by a qualified bicycle mechanic.

REMOVE WHEEL

- Place shifter in gear position "1".
- Loosen the knurled screw (44, **Fig. 1**) and pull the Clickbox off the axle.
- Disengage the red location sleeve (43) and pull it off.
- Remove shift rod (42) and shift tube (41) out of the axle bore.
- Remove wheel.

DISMANTLING HUB

see **Fig. 1**

- Remove circlip (39), sprocket (38) and dust cap (37) as normal.
- Clamp hub by the axle between aluminum jaws with sprocket side facing downwards.
- Unscrew both locknuts (1).
- While turning clockwise, remove lever cone (2) with friction spring (3) and ball retainer (4).

- Take out 3 brake segments (5).
- Withdraw hub sleeve (6) upwards.
- Remove brake cone (7).
- Take out retaining washer (8) and thrust washer (9).
- Remove planetary gear carrier (10), washer (11) compression spring (12) and the three sun gears (13, 14, 15).
- Clamp other axle end.
- Clamp fixed cone (36).
- Remove driver (35), compression spring (33) with cover (32), large compression spring (31), ball retainer (34), gear ring (30) and coupling gear (29).
- Compress spring (26) and remove thrust block (28).
- Remove cover (27), spring (26) and cover (25).
- Dismantle retaining washer (24).
- Remove thrust washer (23) and plastic profile washer (22).
- Unscrew grub screw (17) (Caution: It is subject to spring pressure) – and dismantle the long compression spring (18) guide pin (19), thrust block (20) and the short compression spring (21).

4

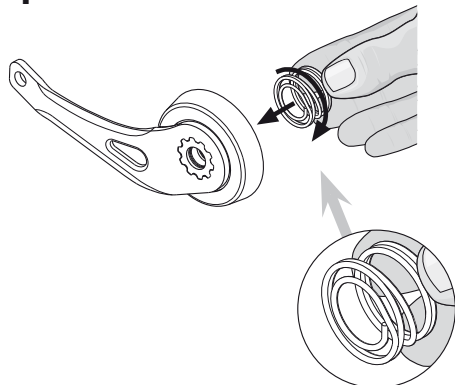

REASSEMBLY HUB

see Fig. 1

Lubrication see "MAINTENANCE / LUBRICATION".

- Insert into the axle (on the side with the internal thread):
Short compression spring (21), thrust block (20) – it is the same both sides, guide rod (19) – it is the same both sides, long compression spring (18).
- Compress spring and fit grub screw (17).
- Clamp axle, end with groove for Clickbox facing upwards.
- Fit plastic profile washer (22) with its large diameter upwards.
- Fit thrust washer (23) and retaining washer (24).
- Locate cover (25), compression spring (26) with 7 turns and cover (27, insides to the spring).
- Compress spring and position thrust block (28) – it is the same both sides – centrally in the axle.
- Clamp other axle end (groove is facing downwards).
- Fit large sun gear (15), with deflector bevels upwards.
- Position medium sun gear (14), with deflector bevels upwards.
- Fit small sun gear (13) – with recesses in front, thrust block engages in the slots.
- Position smallest compression spring (12).
- Fit 1 mm thick washer (11).
- Fit planetary gear carrier (10):
Place the mounting aid (Fig. 2) on the planetary gear carrier such that the markings (X) on the 3 small planet gears and the mounting aid match up.
- Turn planetary gear carrier and at the same time push it downwards over the sun gears.
- Fit thrust washer (9) and retaining washer (8) in the undercut.

Now remove the mounting aid.

Advice:

If the gears are not accurately assembled the hub may feel tight in use. This may lead to gear wheel damage during travel.

- Clamp other axle end (groove for Clickbox facing upwards).
- Fit coupling gear (29) with carrier plate downwards
- Push ring gear (30) over the coupling gear.
- Locate large spring (31).
- Fit largest ball retainer (34) with balls underneath.
- Fit cover (32, inside to the spring).
- Assemble the compression spring (33) with 12 turns.
- Position driver (35) – push it down – and screw on fixed cone (36) to the stop, tightening torque 20 Nm (177 in.lbs.).

- Clamp other axle end (groove for Clickbox is facing downwards).
- Assemble hub shell (6) with a slight counter-clockwise movement.
In case the hub shell jams, position the plastic ring (Fig. 3) correctly. The plastic ring is only fitted to some hub versions.
- Screw brake cone (7) clockwise onto the planetary gear carrier (10) until it stops.
- Insert 3 brake segments (5).
- Turn in friction spring (3) counterclockwise into the lever cone (2) (inlying winding of the spring has to lie against the lever cone) (Fig. 4).
- Insert ball retainer (4) (balls are facing upwards) into lever cone (2): the 3 recesses have to engage into the retaining lugs of the lever cone. Slightly turn ball retainer to prevent it from falling off.
- Fit lever cone onto hub shell: the retaining lugs of the lever cone have to engage into the openings between the brake segments. Make sure that lever cone engages while turning it back and forth slightly.
- Screw on locknuts (1), adjust bearing so that there is no play and lock nuts together with 15 – 20 Nm (133 – 177in.lbs.).

Caution:

Check that all the brake system components are functioning properly!

Advice:

Dismantling and reassembly of hub version without brake should be carried out in the same way.

Differences: Instead of brake segments / cone a click-and-pawl carrier is installed on the planetary gear carrier.

SRAM® S7 MAINTENANCE

5

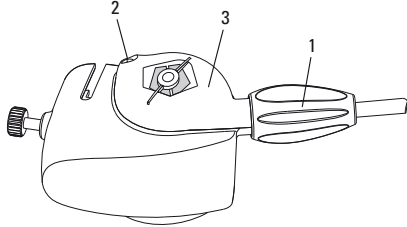

6

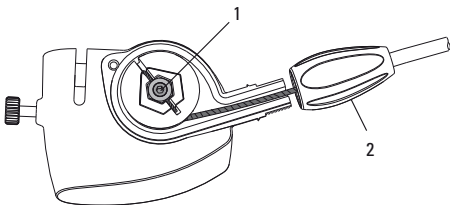

7

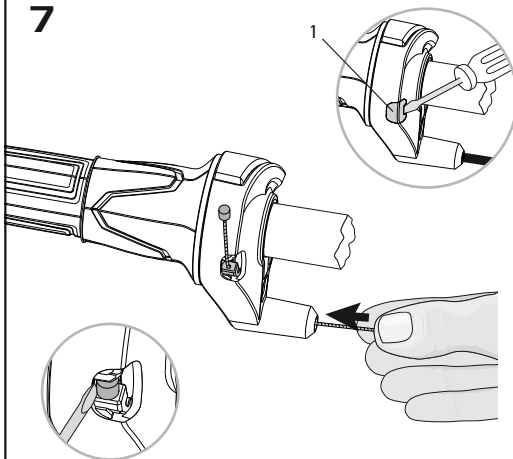

8

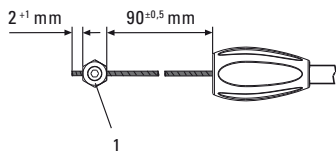

9

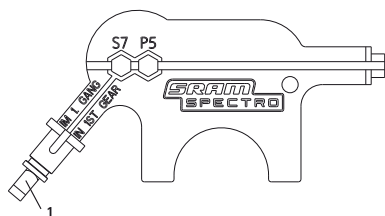

CHANGING THE SHIFT CABLE

Advice:

Always use new, high-quality cables and compressionless cable housings with end caps.

- Turn the twist shifter to 1st gear.

Advice:

Do not remove the Clickbox from the axle end.

- Unscrew the barrel adjuster (1, Fig. 5) completely. Unscrew the cover screw (2), brush aside the barrel adjuster (1) and remove the cover (3).
- Withdraw the shifter cable and clamping bolt (1, Fig. 6) upwards, loosen the clamp screw with a 2.5 mm Allen key and pull the clamping piece from the cable.
- Remove and discard the old cable housing.
- Remove the cap (1, Fig. 7) from the shifter. The nipple of the inner cable is now visible.

- Push or pull the old inner cable (Fig. 7) out of the shifter, e.g. using a small screwdriver.
- Guide the new inner cable into the cable inlet, through the shifter and the new cable housing. Pull the cable tight.
- Insert the cap in the shifter.

- Position clamping bolt (1, Fig. 8) at a distance of 90 mm.

Advice:

For positioning the clamping bolt use adjust gauge (Fig. 9) (Part. No. 65 0324 107 000).

Tighten the clamping screw with a 2.5 mm Allen key. Tightening torque 1.5 Nm (13 in.lbs.).

Cut off the cable end to 2 – 3 mm.

- Locate clamping bolt (1, Fig. 6) and place shifter cable around the carrier cylinder (counter-clockwise winding).
- Position the cover (3, Fig. 5) and tighten up with the cover screw (2). Torque 0.35 – 0.45 Nm (3.1 – 4.0 in.lbs.). Screw in the barrel adjuster (1) completely.

Advice:

- If you want to remove the Clickbox from the axle end for changing the cable, do as follows:

- Place shifter in gear position "1".
 - Loosen the knurled screw and pull the Clickbox off the axle.
 - Now it's essential to push the end (1, Fig. 9) of the adjust gauge completely into the Clickbox and tighten up the knurled bolt (so that you maintain the initial tension of the spring inside the Clickbox).
 - Change cable as per description above.
- If you remove the Clickbox from the axle and change the cable without using the end of the adjust gauge, then you will lose the initial tension of the spring inside the Clickbox. In this case you must assemble the cable by placing it around the carrier cylinder with an additional winding (Fig. 6).

- Adjust the gears as described on page 71.